

ERRATA for
Civil PE Sample Questions and Solutions
Copyright 2008
ISBN: 978-1-932613-31-5
Errata posted 06-23-2009

Breadth Module

p. 31, Breadth Question 106:

Change line 4 as follows:

Plastic limit 25

p. 34, Breadth Question 114:

Beginning with the April 2008 exam, traffic analysis is not covered in the Transportation portion of the Breadth exam. The Transportation portion of the Breadth exam will only contain questions about geometric design. The following is another example of a geometric design question.

The back tangent of a horizontal curve has a bearing of N 65°48'00" E. The ahead (forward) tangent has a bearing of S 71°24' E. The bearing from the PI to the center is most nearly:

- (A) S 2°48' E
- (B) S 40°00' E
- (C) S 60°48' E
- (D) S 61°40' E

Breadth Solution:

Solving for Δ ,

$$90^\circ - 65^\circ 48' 00'' = 24^\circ 12'$$

$$90^\circ - 71^\circ 24' 00'' = 18^\circ 36'$$

$$\Delta = 24^\circ 12' + 18^\circ 36' = 42^\circ 48'$$

$$\Delta/2 = 42^\circ 48'/2 = 21^\circ 24'$$

Now solving for the angle subtended by the forward tangent to the line between the PI and center of curve,

$$90^\circ - \Delta/2 = 90^\circ - 21^\circ 24' = 68^\circ 36'$$

$$\text{Bearing} = 71^\circ 24' - 68^\circ 36' = \text{S } 2^\circ 48' \text{ E}$$

THE CORRECT ANSWER IS: (A)

ERRATA for
Civil PE Sample Questions and Solutions
 Copyright 2008
 ISBN: 978-1-932613-31-5
 Errata posted 06-23-2009

Breadth Module (Continued)

p. 139, Breadth Solution 106:

Add the following equation to the solution:

$$\begin{aligned} PI &= 55 - 25 \\ &= 30 \end{aligned}$$

Construction Module

p. 47, Construction Question 508:

Replace the existing figure with the following:

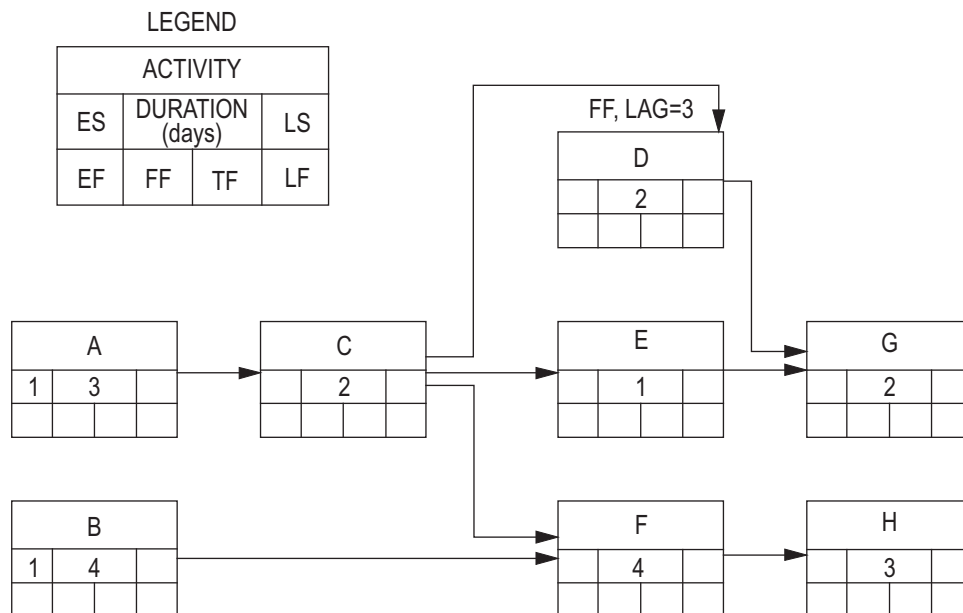

ERRATA for
Civil PE Sample Questions and Solutions
Copyright 2008
ISBN: 978-1-932613-31-5
Errata posted 06-23-2009

Construction Module (Continued)

p. 48, Construction Question 509:

Change the first sentence as follows:

In the activity-on-arrow network below, based on end-of-day calculations for starts and finishes, the early start of Activity N is most nearly:

p. 50, Construction Question 511:

Change the first sentence as follows:

A formal CPM analysis for a project shows the planned costs to date are \$85,000, and the accounting department reports charges to the job of \$95,000.

p. 54, Construction Question 518:

Change line 2 as follows:

The OSHA incidence rate for recordable cases is most nearly:

p. 149, Construction Solution 504:

Change line 5 as follows:

$$\text{Costs} = 9,000 \left(\frac{A}{P} \right)_{5 \text{ yr}}^{10\%} + 1,000 (0.10)$$

Change line 8 as follows:

$$\text{Costs} = 10,000 \left(\frac{A}{P} \right)_{5 \text{ yr}}^{10\%} - 1,000 \left(\frac{A}{F} \right)_{5 \text{ yr}}^{10\%}$$

p. 155, Construction Solution 518:

Change the second sentence as follows:

The term *incidence rate* for recordable cases means the number of injuries and illnesses requiring treatment beyond first aid, those that result in lost workdays, and those that result in restricted or light duty, per 100 full-time workers.

ERRATA for
Civil PE Sample Questions and Solutions
Copyright 2008
ISBN: 978-1-932613-31-5
Errata posted 06-23-2009

Geotechnical Module

p. 69, Geotechnical Question 513:

Change sentence 2 as follows:

For Layer 3, the earthquake-induced average shear stress is 450 psf, and the cyclic stress ratio is 0.29.

p. 74, Geotechnical Question 516:

Option (A) should read as follows:

(A) 2,700

p. 75, Geotechnical Question 517:

Options (A) through (D) are as follows:

- (A) 1.6
- (B) 1.7
- (C) 1.9
- (D) 2.3

p. 165, Geotechnical Solution 516:

Replace the existing solution with the following:

Reference: Boyles, Joseph E., *Foundation Analysis and Design*, 5th ed., pp. 220–227.

Given: Square footing $B = L = 5$ ft
 $D_f = 2$ ft

$\gamma = 115$ pcf
 $c = 200$ psf
 $\phi = 20^\circ$

Given: Bearing-capacity factors $N_c = 14.8$
 $N_q = 6.4$
 $N_\gamma = 5.4$

ERRATA for
Civil PE Sample Questions and Solutions
Copyright 2008
ISBN: 978-1-932613-31-5
Errata posted 06-23-2009

Geotechnical Module (Continued)

p. 165, Geotechnical Solution 516 (Continued):

For $N_\gamma = 5.4$ for $\phi = 20^\circ$, Vesic's bearing-capacity equation is applicable:

$$q_{ult} = cN_c s_{c(V)} d_{c(V)} + \bar{q} N_q s_{q(V)} d_q + 0.5 \gamma B' N_\gamma s_{\gamma(V)} d_\gamma$$

Shape and depth factors:

$$s_{c(V)} = 1.0 + \left(\frac{N_q}{N_c} \right) \left(\frac{B}{L} \right) = 1 + \left(\frac{6.4}{14.8} \right) \left(\frac{5}{5} \right) = 1.432$$

$$d_c = 1.0 + 0.4 \left(\frac{D}{B} \right) = 1 + 0.4 \left(\frac{2}{5} \right) = 1.16$$

$$s_{q(V)} = 1.0 + \frac{B}{L} \tan \phi = 1.0 + \frac{5}{5} \tan (20^\circ) = 1.364$$

$$d_q = 1 + 2 \tan \phi (1 - \sin \phi)^2 \left(\frac{D}{B} \right) = 1 + 2 \tan 20^\circ (1 - \sin 20^\circ)^2 \left(\frac{2}{5} \right) = 1.126$$

$$s_{\gamma(V)} = 1.0 - 0.4 \left(\frac{B}{L} \right) = 1 - 0.4 \left(\frac{5}{5} \right) = 0.6$$

$$d_\gamma = 1.00$$

$$\begin{aligned} q_{ult} &= [(200)(14.8)(1.432)(1.16)] + [(2)(6.4)(115)(1.364)(1.126)] + [(0.5)(115)(5)(5.4)(0.6)(1.0)] \\ &= 8,109.21 \text{ psf} \end{aligned}$$

Given FS = 3.0

$$q_{allowable} = \frac{q_{ult}}{FS} = \frac{8,109.21}{3} = 2,703.07 \text{ psf}$$

THE CORRECT ANSWER IS: (A)

ERRATA for
Civil PE Sample Questions and Solutions
Copyright 2008
ISBN: 978-1-932613-31-5
Errata posted 06-23-2009

Geotechnical Module (Continued)

p. 166, Geotechnical Solution 517:

Replace resisting moment equation with the following:

$$\text{Resisting moment} = (2)(9)(155)(4.5) + (5)(18)(155)(4.5) + (2)(18)(105)(8) = 105,570 \text{ ft-lb}$$

Replace calculation of FS with the following:

$$\text{FS} = \frac{105,570}{46,200} = 2.28$$

THE CORRECT ANSWER IS: (D)

p. 166, Geotechnical Solution 518:

Replace calculation of average overburden pressure with the following:

$$P_o = \frac{5(120) + 30(115)}{2} = 2,325 \text{ psf}$$

ERRATA for
Civil PE Sample Questions and Solutions
Copyright 2008
ISBN: 978-1-932613-31-5
Errata posted 06-23-2009

Structural Module

p. 82, Structural Question 503:

Options (A) through (D) are as follows:

- (A) 250
- (B) 75
- (C) 50
- (D) 36

p. 86, Structural Question 506:

Add an assumption:

Neglect block shear and the capacity of the connection.

Options (A) through (D) are as follows:

- (A) $\perp\perp 2\ 1/2 \times 2\ 1/2 \times 3/8$
- (B) $\perp\perp 3\ 1/2 \times 3\ 1/2 \times 5/16$
- (C) $\perp\perp 3\ 1/2 \times 3\ 1/2 \times 3/8$
- (D) $\perp\perp 4 \times 4 \times 3/8$

p. 100, Structural Question 518:

Options (A) through (D) are as follows:

- (A) 16
- (B) 24
- (C) 29
- (D) 38

ERRATA for
Civil PE Sample Questions and Solutions
 Copyright 2008
 ISBN: 978-1-932613-31-5
 Errata posted 06-23-2009

Structural Module (Continued)

p. 172, Structural Solution 503:

Change lines 6, 7, 8, and 9 as follows:

$$\text{Total weight} = 70 \text{ kips} + 36 \text{ kips} = 106 \text{ kips} \times 0.6 = 63.6 \quad (\text{ASCE 7 -05, part 2.4.1})$$

$$\text{Weight per leg} = 106 \text{ kips}/4 = 26.5 \text{ kips} \times 0.6 = 15.9$$

$$\begin{aligned} \text{Net uplift} &= -50 \text{ kips} + 15.9 \text{ kips} \\ &= 36.1 \text{ kips} \end{aligned}$$

pp. 174–175, Structural Solution 506:

Replace the existing solution with the following:

ASD Provisions:

$$P \leq \frac{P_n}{\Omega} \quad (\text{Eq. B3-2})$$

Check tensile yield:

$$P_n = F_y A_g \text{ with } \Omega_t = 1.67 \quad (\text{D2-1})$$

$$\therefore 85 \text{ kips} \leq \frac{F_y A_g}{\Omega_t} = \frac{(36 \text{ ksi}) A_g}{1.67}$$

$$A_{g \text{ min}} \geq \frac{(85 \text{ kips})(1.67)}{36 \text{ ksi}} = 3.94 \text{ in}^2 \quad \text{select smallest area with } A_g \geq 3.94 \text{ in}^2.$$

$$\therefore \text{Try } \text{—L } 3 \frac{1}{2} \times 3 \frac{1}{2} \times 5/16$$

$$A_g = 4.21 \text{ in}^2 \geq A_{g \text{ min}} = 3.94 \text{ in}^2 \quad \therefore \text{OK}$$

Check tensile rupture:

$$P_n = F_u A_e \text{ with } \Omega_t = 2.00 \quad (\text{D2-2})$$

$$85 \text{ kips} < \frac{F_u A_e}{2.00}$$

$$A_e = A_n U \quad (\text{p. 16.1-28})$$

$$A_n = [(4.21 \text{ in}^2) - 2(7/8 \text{ in.} + 1/16 \text{ in.} + 1/16 \text{ in.})(5/16 \text{ in.})]$$

$$A_n = 3.585 \text{ in}^2$$

ERRATA for
Civil PE Sample Questions and Solutions
 Copyright 2008
 ISBN: 978-1-932613-31-5
 Errata posted 06-23-2009

Structural Module (Continued)

Structural Solution 506 (continued):

All elements of angle not connected,

$\therefore U \neq 1 \rightarrow$ Shear lag

(Table D3.1)

Per code, permissible to use largest "U"

Case 8 \rightarrow Table D3.1

$U = 0.6$ (3 fasteners/line)

Case 2

$$U = 1 - \frac{\bar{x}}{l} = 1 - \frac{0.979 \text{ in.}}{6 \text{ in.}} = 0.837$$

Largest $U = 0.837 \rightarrow$ lightest $\angle L$

$$A_e = (3.585 \text{ in}^2)(0.837) = 3.00 \text{ in}^2$$

$$85 \text{ kips} \leq \frac{(58 \text{ ksi})(3.00 \text{ in}^2)}{2.0} = 87.0 \text{ kips} \quad \therefore \text{OK}$$

Use $\angle L \ 3 \ 1/2 \times 3 \ 1/2 \times 5/16$

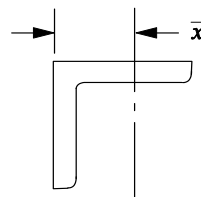

THE CORRECT ANSWER IS: (B)

LRFD Provisions:

$$P_u \leq \phi_t P_n \tag{B3-1}$$

Check tensile yield:

$$P_n = F_y A_g \tag{D2-1}$$

$$P_u = \phi_t F_y A_g \text{ with } \phi_t = 0.9$$

$$130 \text{ kips} \leq 0.9 (36 \text{ ksi}) A_g$$

$$A_{g \min} \geq \frac{(130 \text{ kips})}{(0.9)(36 \text{ ksi})} = 4.01 \text{ in}^2$$

$$A_g = 4.21 \text{ in}^2 > A_{g \min} = 4.01 \text{ in}^2$$

\therefore Try $\angle L \ 3 \ 1/2 \times 3 \ 1/2 \times 5/16$

ERRATA for
Civil PE Sample Questions and Solutions
 Copyright 2008
 ISBN: 978-1-932613-31-5
 Errata posted 06-23-2009

Structural Module (Continued)

Structural Solution 506 (continued):

Check tensile rupture:

$$P_u \leq \phi_t F_u A_e$$

$$130 \text{ kips} \leq 0.75 (58 \text{ ksi}) A_e$$

$$A_e = A_n U = [(4.21 \text{ in}^2) - (7/8 \text{ in.} + 1/16 \text{ in.} + 1/16 \text{ in.})(5/16 \text{ in.})(2)] (0.837)$$

$$U = 0.837 \text{ (from ASD)}$$

$$A_e = 3.00 \text{ in}^2$$

$$P_u \leq \phi_t F_u A_e$$

$$130 \text{ kips} \leq 0.75 (58 \text{ ksi})(3.00 \text{ in}^2) = 130.5 \text{ in}^2 \quad \therefore \text{OK}$$

\therefore Use $\text{L}3 \text{ } 1/2 \times 3 \text{ } 1/2 \times 5/16$

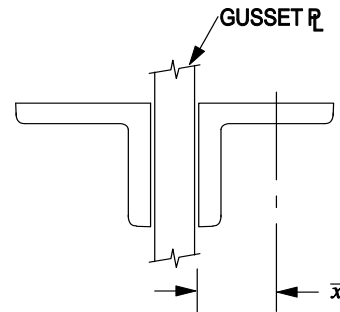

THE CORRECT ANSWER IS: (B)

p. 177, Structural Solution 510:

The following information clarifies the existing solution.

The critical section for shear occurs at the distance d from the face of the columns. In this case, the section must be checked on the far, or exterior, side of the columns.

From the critical bending shear calculation,

8'-0" is the center of footing to center of column

1'-0" is the center of footing to outside face of column

3'-0" is d , effective footing depth

10'-0" is the width of the footing.

ERRATA for
Civil PE Sample Questions and Solutions
Copyright 2008
ISBN: 978-1-932613-31-5
Errata posted 06-23-2009

Structural Module (Continued)

p. 182, Structural Solution 518:

Replace calculation of F_{SR} with the following:

$$F_{SR} = \left(\frac{250(10^8)}{48 \times 365 \times 25} \right)^{0.333} = (57,077)^{0.333} = 38.4 \text{ ksi} > F_{TH} = 24$$

Transportation Module

p. 192, Transportation Solution 511:

Replace lines 2, 3, 7, and 8 with the following:

$$S_1 = (V_1^2 - V_f^2) / 30f$$

$$25 = (V_1^2 - (30)^2) / (30 \times 0.55)$$

$$S_2 = (V_2^2 - V_1^2) / (30 \times 0.71)$$

$$(150 + 24) = (V_2^2 - (36.23)^2) / (30 \times 0.71)$$

Water Resources and Environmental Module

p. 122, Water Resources and Environmental Question 501:

Change sentence 2 as follows:

The elevation of the hydraulic grade line at an open reservoir is 495 ft at the beginning and 365 ft at the end.

ERRATA for
Civil PE Sample Questions and Solutions
Copyright 2008
ISBN: 978-1-932613-31-5
Errata posted 06-23-2009

Water Resources and Environmental Module (Continued)

p. 127, Water Resources and Environmental Question 510:

Change first sentence as follows:

Regional groundwater flow through a sandstone aquifer (porosity = 0.3) is shown in the figure below.

Options (A) through (D) are as follows:

- (A) 0.5
- (B) 20
- (C) 1,100
- (D) 3,700

p. 207, Water Resources and Environmental Solution 508:

The following information clarifies the existing solution.

Rainfall 1 is from time = 0 hr to time = 1 hr at an intensity of 1.5 in./hr.

Rainfall 2 is from time = 1 hr to time = 2 hr at an intensity of 0.7 in./hr.

The discharge in the watershed during the second hour will consist of:

The second hour of Rainfall 1 ($1.2 \text{ cfs/in.} \times 1.5 \text{ in./hr} \times 1 \text{ hr}$) plus the first hour of Rainfall 2 ($0.5 \text{ cfs/in.} \times 0.7 \text{ in./hr} \times 1 \text{ hr}$), or 2.15 cfs.

ERRATA for
Civil PE Sample Questions and Solutions
Copyright 2008
ISBN: 978-1-932613-31-5
Errata posted 06-23-2009

Water Resources and Environmental Module (Continued)

p. 208, Water Resources and Environmental Solution 510:

Replace the existing solution with the following:

Applying Darcy's equation, the Darcy velocity can be found as:

$$\begin{aligned}V &= -K \frac{dh}{dL} \approx -K \frac{\Delta h}{\Delta L} \\ &= 15 \text{ ft/day} \left(\frac{200 \text{ ft}}{12 \times 5,280 \text{ ft}} \right) \\ &= 0.047 \text{ ft/day (this is the Darcy velocity)}\end{aligned}$$

The seepage velocity or the linear velocity is therefore:

$$\frac{\text{Darcy velocity}}{\text{porosity}} = \frac{0.047 \text{ ft/day}}{0.3} = 0.157 \text{ ft/day}$$

$$\therefore \text{Travel time} = \frac{12 \times 5,280 \text{ ft}}{0.157 \text{ ft/day}} = 403,566 \text{ days} = 1,105 \text{ years}$$

THE CORRECT ANSWER IS: (C)

p. 213, Water Resources and Environmental Solution 517:

Change line 2 as follows:

$$= 2.1 \times 10^9 \text{ ft}^3/\text{day} \times 172 \text{ mg/L} \times 28.32 \text{ L/ft}^3 \times \text{lb}/4.54 \times 10^5 \text{ mg}$$